



QUANTUM

DDQ 60 • DDQ 160 • DDQ 400

AIR-OPERATED DOUBLE DIAPHRAGM PUMPS

SOLID-BLOCK CONSTRUCTION

MADE OF PTFE • UPPE

1/2" • 1" • 1 1/2"



SINCE 1975

EN

THE NEW ORIGINAL AODD PUMPS

MADE OF UPPE • PTFE

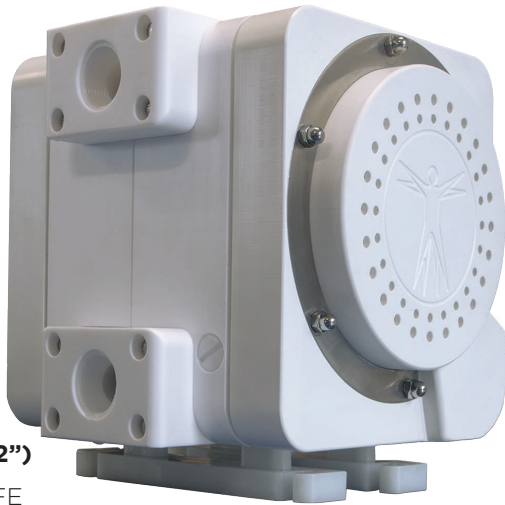

DDQ 60 (1/2")

made of PTFE

MAIN CHARACTERISTICS

- Run-dry
- Self-priming
- No use of power
- Variable flow and pressure
- Free-fastening diaphragms

TYPICAL APPLICATIONS

QUANTUM pumps can operate in various applications as “transfer pumps” and thanks to their resistance, they can pump any chemical fluid:

- corrosive and non-corrosive liquids
- with a high or low viscosity
- with solids and abrasive particles
- shear sensitive
- inflammable ones

EXAMPLES

Industries	Applications
Chemical and Pharmaceutics	acids, alkalis, alcohol, solvents, emulsions, ultra pure liquids
Semiconductors	heat transfer and ultra pure liquids, electrolyte solutions, mercure, solvents
Surface treatments	galvanic baths, acids, solvents, sludge, varnishes, enamels
Water treatments	neutralisation, flocculation
Paper and Printing	glues additives, varnishes, inks, latex, acids, resins, pigments, sludge, adhesives, sodium silicate, titanium oxide
Photovoltaic	ultra pure liquids, sludge, abrasive solvents

QUANTUM are the new original AODD pumps made by **Argal**. They offer, in addition to optimised performance, a great equilibrium between efficiency and sustainability.

Thanks to the solid-block construction made of the thermoplastic polymer UPPE and fluoro-polymer PTFE, these new members of the family have a very high chemical resistance and mechanical strength, allowing the pumping of all hard chemical liquids.

Inside **QUANTUM**, the liquid pumped is directly and linearly dragged to the central casing, reducing friction and loss, with no manifold needed.

Beyond the robustness, the pumps ensure an air consumption reduction, a longer life cycle and the recycling of components.

- Dead-head (delivery pipe closed)
- ATEX conformity
- Easy maintenance
- Air consumption reduction
- No ice formation
- Inlet pressure up to 7 bar

MATERIALS

PTFE material is a fluoroplastic polymer with unlimited chemical resistance. Pumps made of PTFE can drag any chemical: acids, mixtures, hydroxide and basic acids. A working pump can handle liquids with temperatures up to 100°C.

UPPE (Ultra High Molecular Weight Polyethylene) is a thermoplastic polymer with a high abrasion resistance as well as high resistance to hard liquids. A working pump can handle liquids with temperatures from -40°C up to +70°C.

ATEX

QUANTUM pumps are suitable to operate in explosive atmospheres classified **Zone 2 (Series II 3/3 GD IIB T4)**. For applications classified **Zone 1 (Series II 2/2 GD IIB T4)**, we manufacture pumps made of conductive parts for all versions.

TEMPERATURES

	PTFE	UPPE
ambient temperatures	-40°C - +60°C	- 60°C - +40°C
operative temperatures	-40°C - + 100°C	-40°C - +70°C

DDQ 60

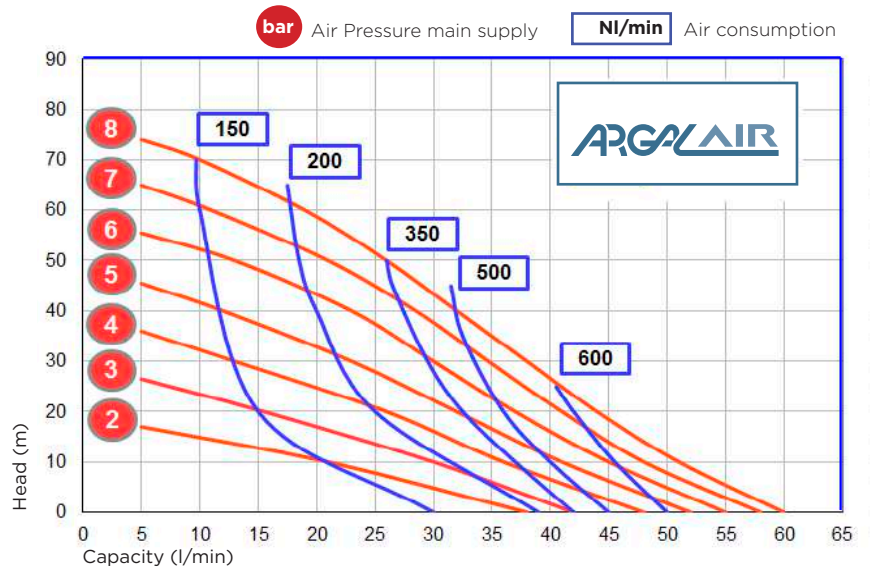

DDQ 160

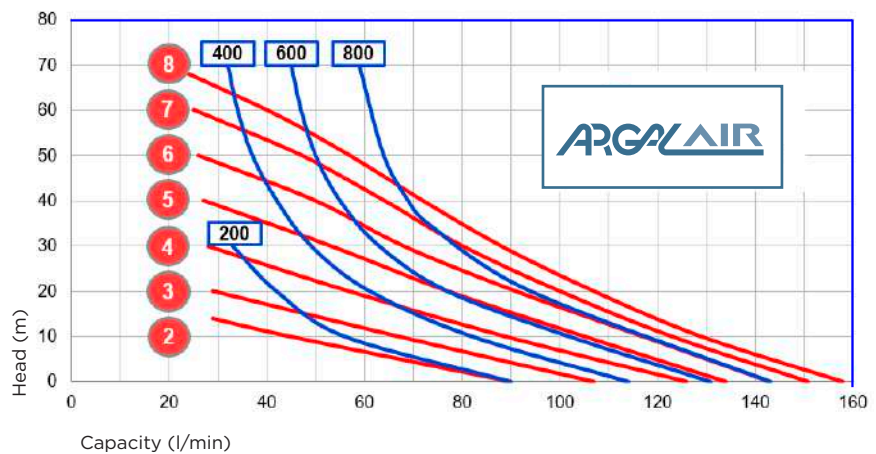

DDQ 400

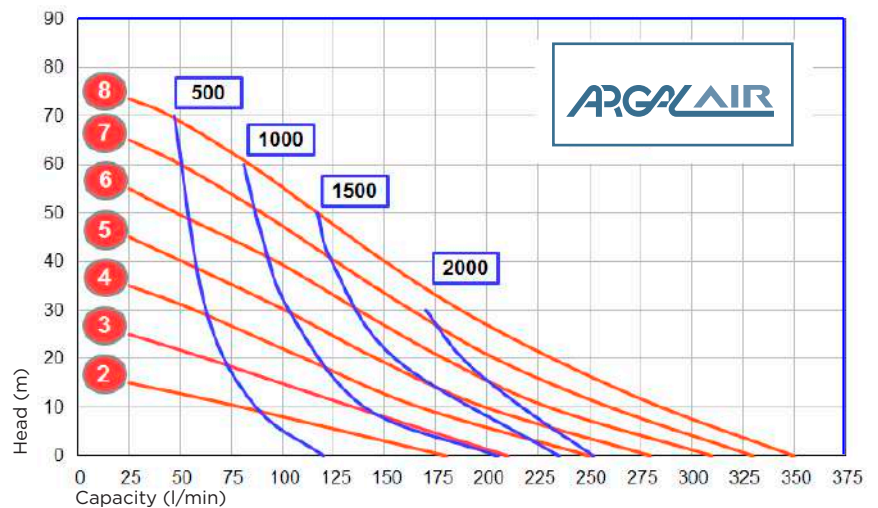

TECHNICAL DATA

DDQ 60 • DDQ 160 • DDQ 400

Fluid inlet	G ½" BSP
Air inlet	G ¼" BSP
Max flow rate	60 l/m'
Max working pressure	8 bar
Delivery head	80 mca
Max suction lift dry	4 mca
Max suction lift wet	9 mca
Max solids size	7,5 mm
Noise	78 dB(A)
Weight	6,8 kg (UPPE) 9,9 kg (PTFE)

DIMENSIONS (mm)	
DDQ 60	A 220 B 210 C 186

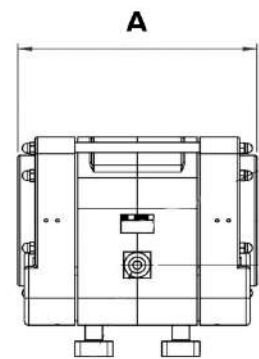
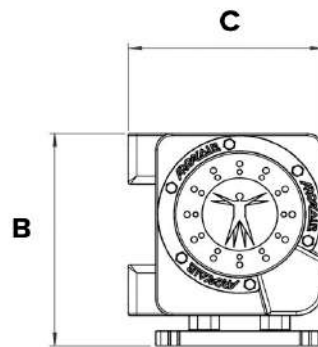

Fluid inlet	G 1" BSP
Air inlet	G ¾" BSP
Max flow rate	160 l/m'
Max working pressure	8 bar
Delivery head	80 mca
Max suction lift dry	4 mca
Max suction lift wet	9 mca
Max solids size	11 mm
Noise	80 dB(A)
Weight	11,7 kg (UPPE) 18,5 kg (PTFE)

DIMENSIONS (mm)	
DDQ 160	A 270 B 250 C 227

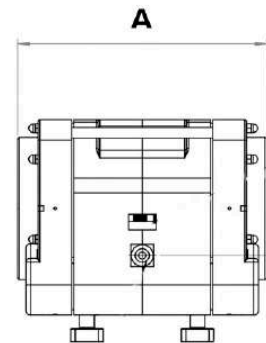
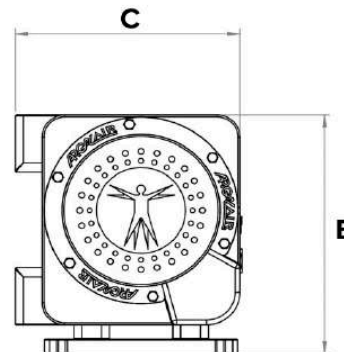

Fluid inlet	G 1 ½" BSP
Air inlet	G ½" BSP
Max flow rate	400 l/m'
Max working pressure	8 bar
Delivery head	80 mca
Max suction lift dry	4 mca
Max suction lift wet	9 mca
Max solids size	19 mm
Noise	83 dB(A)
Weight	27,5 kg (UPPE) 43,5 kg (PTFE)

DIMENSIONS (mm)	
DDQ 400	A 381 B 330 C 310

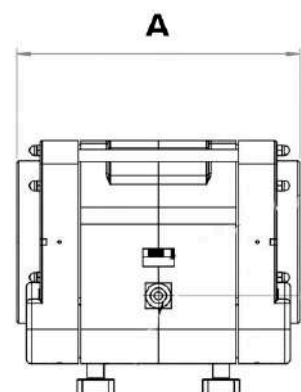
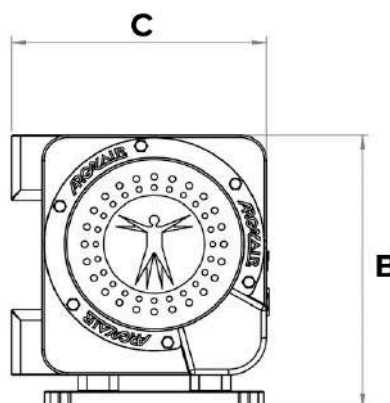

QUANTUM'S PLUS

INNOVATIVE COMPONENTS



DOUBLE DIAPHRAGM

The QUANTUM pumps construction also included free-fastening diaphragms. This allows easy maintenance, more safety while pumping aggressive liquids and important reduction of air consumption.



VALVES

It's possible to disassemble the valves for maintenance without disassembling the entire pump already onsite.



FREE ICE FORMATION SYSTEM

It is known that AODD pumps are usually suffering from ice formation in the distribution system. The QUANTUM pumps are an innovative solution allowing to redirect exhausted air, at low temperature, towards the discharge chamber. Thanks to this, the PADS is utterly insensitive to humidity in the air, so there is no influence on the efficiency.

DISCHARGE SYSTEM

QUANTUM's DDQ 1" and DDQ 1 1/2" models are equipped with internal pipes to remove the liquid from the pump entirely: an efficient and accurate way for improving the operativity and functionality of the pump.

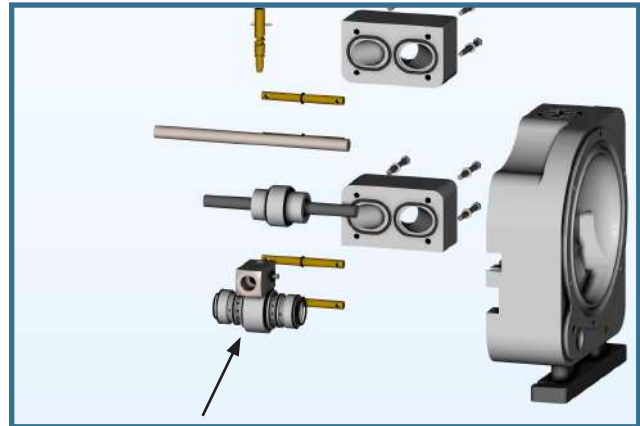

SMART PADS

A new simple, compact and highly efficient air distribution system was conceived. It is equipped with an air capacity regulator - without interfering with the pressure used in the control units.

Thanks to the quick discharge valve, a considerable air consumption reduction is noted (up to -30%).

The QUANTUM pumps can, therefore, operate in any work condition.

SECURITY SYSTEM

In addition to the longer life cycle, QUANTUM also offers a great advantage: the pump guarantees a major security for operators and the pump itself. The innovation is that, if the diaphragm broke, the pumped liquid would not return to the air supply line.

MAG-DRIVE &
MECH-SEALED
CENTRIFUGAL
PUMPS

PNEUMATIC
AODD &
METERING
PUMPS
PULSATION
DAMPENERS

SUBMERSIBLE
PUMPS



SELF-PRIMING
PUMPS

VERTICAL
SUMP PUMPS

ARGAL srl

Via Labirinto, 159 - 25125 BRESCIA - (Italy)
Phone +39 030 3507011 - fax +39 030 3507077
info@argal.it - www.argalpumps.com



cod. 03.2018 - EN